

## One-way intercom

You are going to send voice messages via a modulated current in a pair of wires. The modulator circuit is shown below.

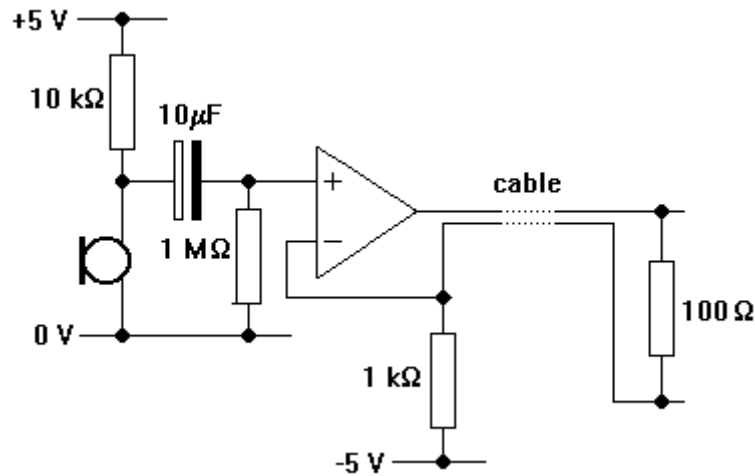

- 1 Assemble the circuit. Don't bother with the cable for the moment. Simply connect the 100 Ω resistor in its place.
- 2 Use an oscilloscope to look at the output of the op-amp. If all is well, there should be a steady +500 mV when there is no sound. Speaking into the microphone should add a small a.c. component to this signal.
- 3 Assemble the demodulator circuit shown below on a separate breadboard. Use an earphone as the speaker.

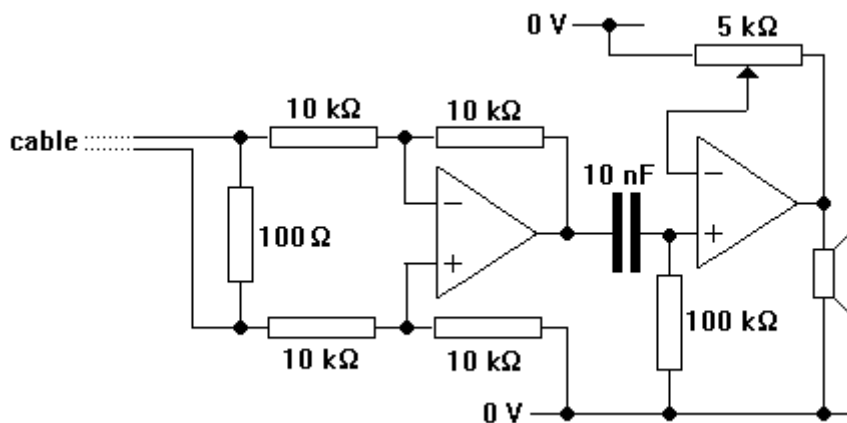

- 4 Connect the modulator and demodulator with a pair of wires twisted together to make a long cable. The longer the better. If all is well, the output of the difference amplifier should be a steady +500 mV, with the a.c. signal from the microphone superimposed on it. The potentiometer adjusts the voltage gain of the amplifier which drives the speaker.
- 5 Use an oscilloscope to look at the signals arriving at the demodulator along the cable. You should find that both wires have picked up a lot of noise on their way from the modulator. Most of that noise should be eliminated by the demodulator.